

Batterieuse

Will Buchanan, Zach Badger-Markey, Ricky Powell, Louis Quicksell

Lithium-Ion Battery Landscape

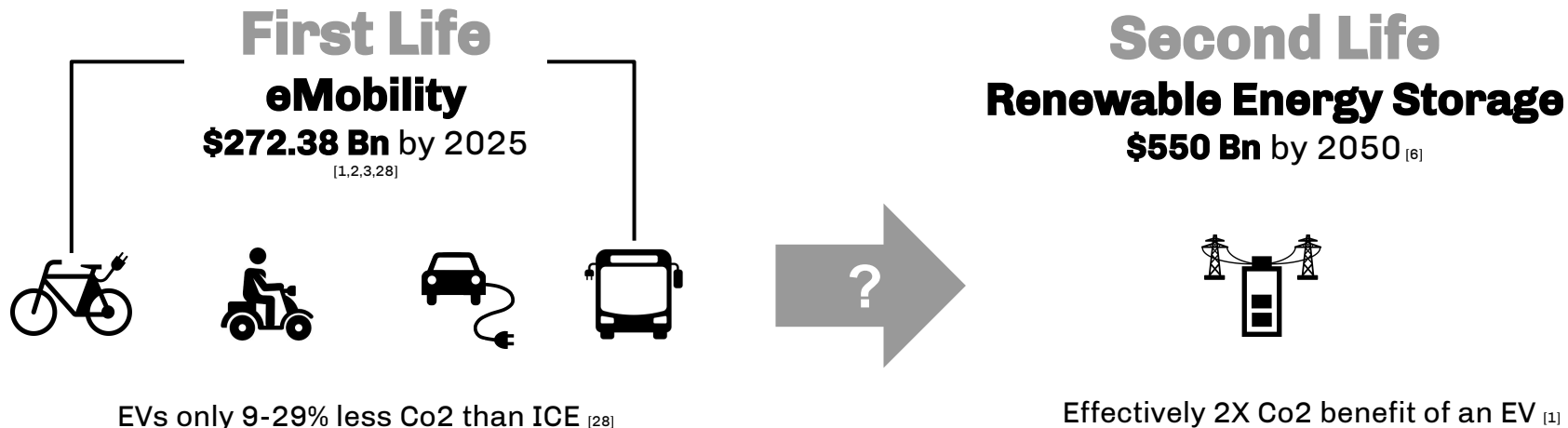

Solution

A **data pipeline** collecting **usage data** & enables **performance & degradation** insights

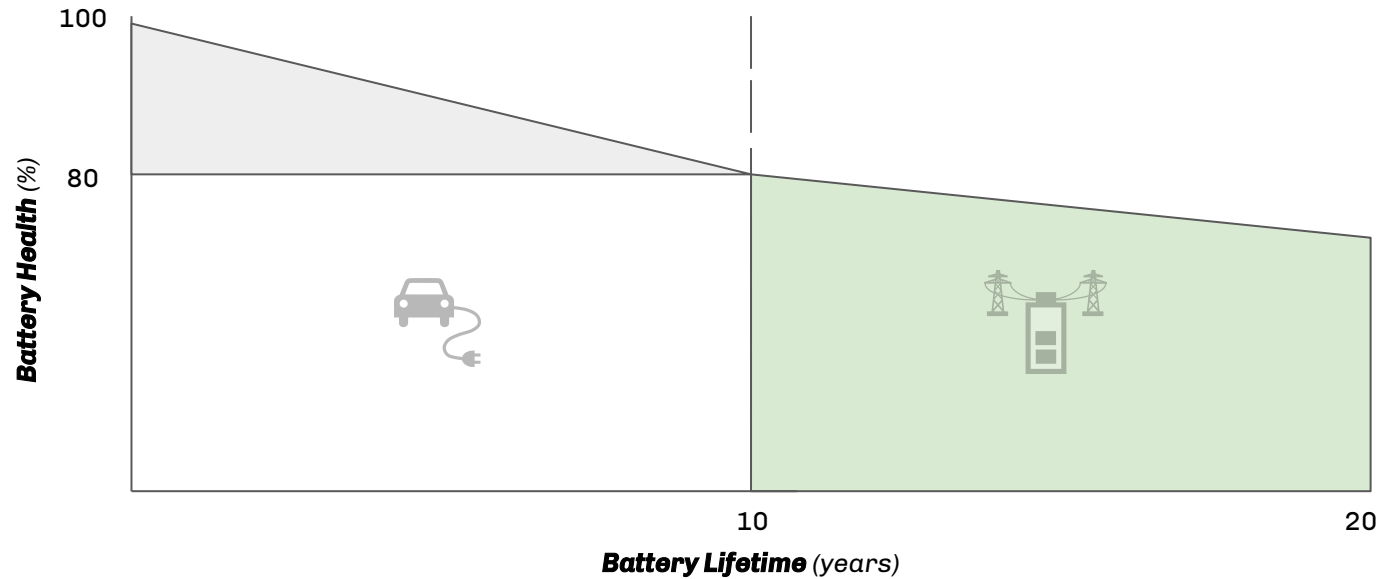

What Is A Battery Management System?

- **The “brains” of a battery**
- **Inputs:**
 - Current, voltage & temperature
- **Functionalities:**
 - State of Charge (SoC)
 - Cell balancing
 - Safety
- **How long will a battery last?**
 - **“Batteries are like people”**
 - Rate of charge/discharge (C-rate)
 - Depth of discharge (DoD)
 - State of charge/time (SoC)
 - Temperature

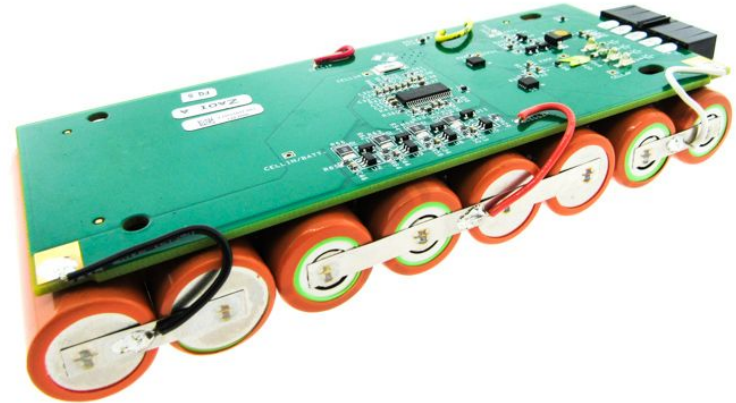

Battery Management System

BattGenie



- Early-stage UW spinoff
- 20+ years in battery modeling
- Physics simulation
- No additional hardware
- **Accurate** parameters
 - Increased depth of discharge
 - Superior profile (vs. CC-CV)
 - ~23% faster charging
 - ~**100% increase in cycle life**

Extended Lifespan

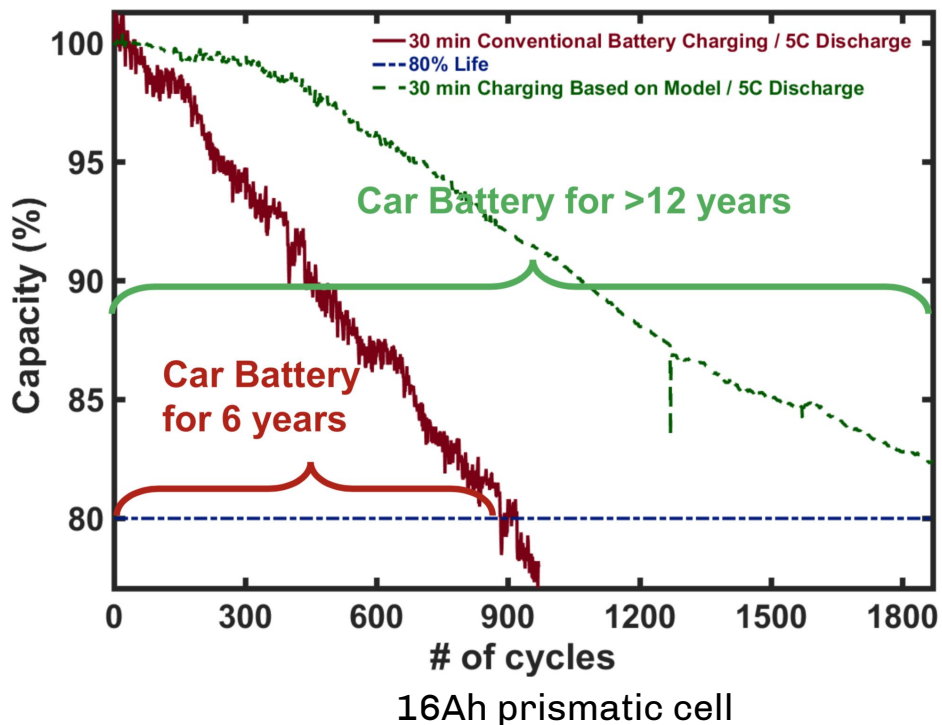

Project Phases



Market Exploration

Objective:

Determine project application

Research:

Secondary research
Stakeholder mapping
Decision matrix

Conclusion:

Develop eBike battery management system (BMS) to facilitate repurposing

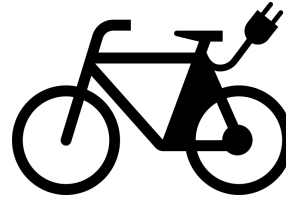

eBike BMS

Objective:

eBike BMS to facilitate repurposing

Research:

Market research
SME interviews
Prototype evaluation testing

Conclusion:

Develop ledger for repurposing eMobility batteries



Battery Ledger (CarFax)

Objective:

Ledger for repurposing batteries

Research:

Contextual inquiry
SME interviews
Prototype evaluation testing

Conclusion:

Focus data pipeline for repurposing batteries

Refined Solution

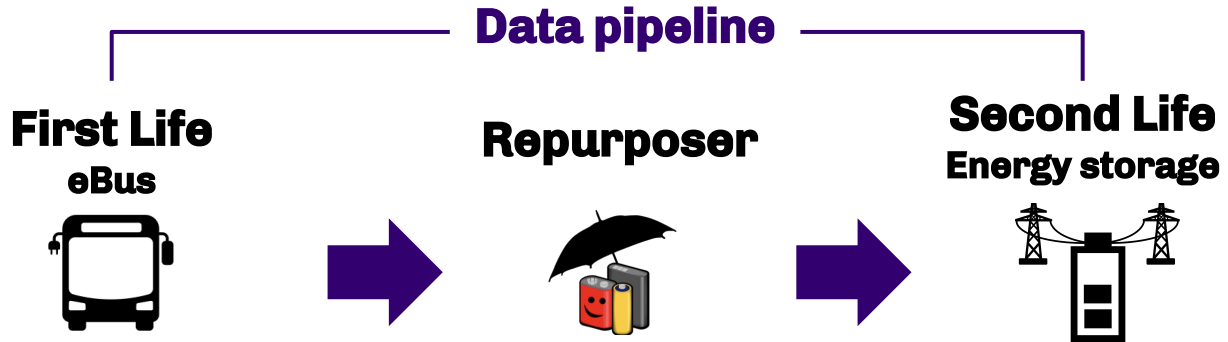

<i>Partners</i>	Transit Agency	BattGenie	Utility Provider
<i>Needs</i>	<ul style="list-style-type: none"> - Retirement schedule - Save recycling costs 	<ul style="list-style-type: none"> - Battery performance monitoring 	<ul style="list-style-type: none"> - Optimal ROI - Confidence
<i>Features</i>	Replacement schedule	Battery-level dashboard	System-level overview

System Diagram

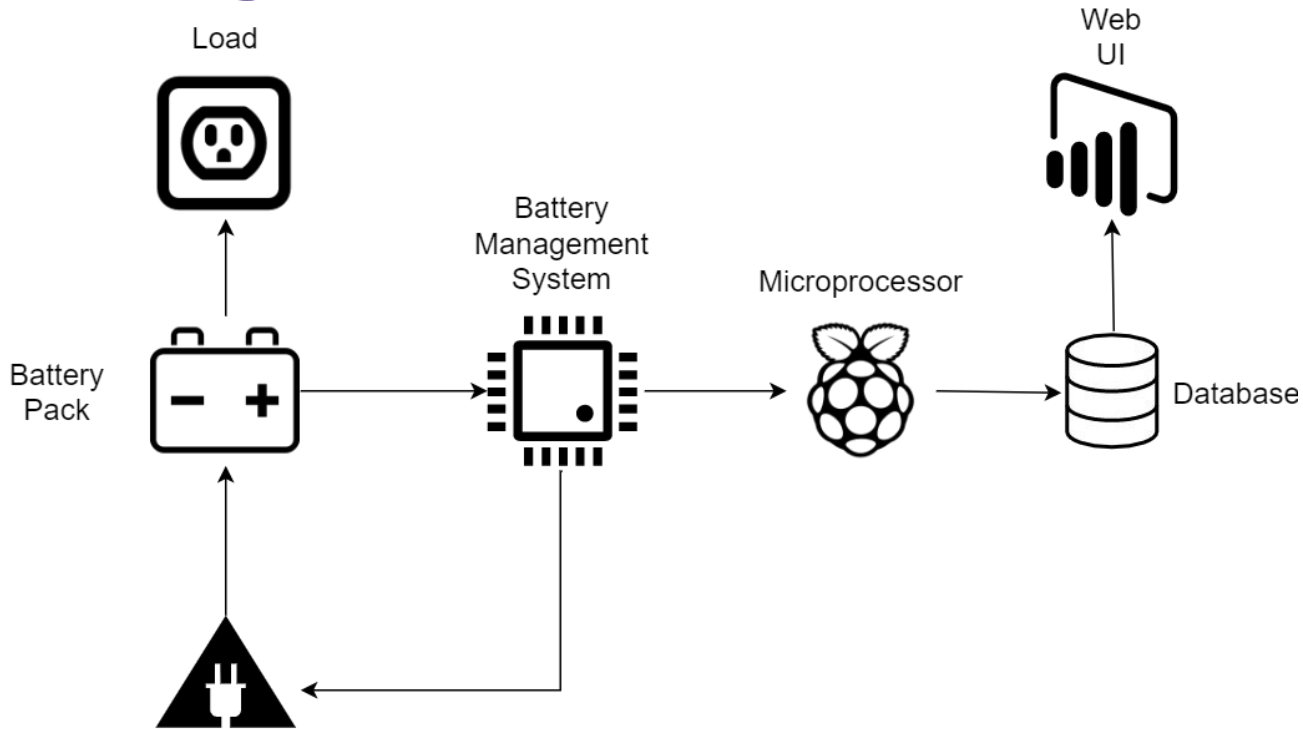

Arduino
Signal Processing

Current Sensor

Voltage Reader
Series-level data

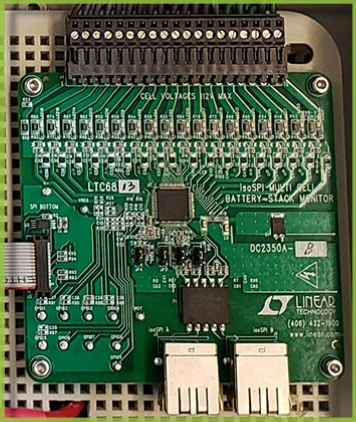
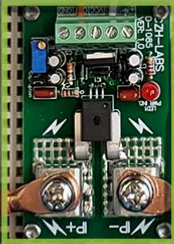
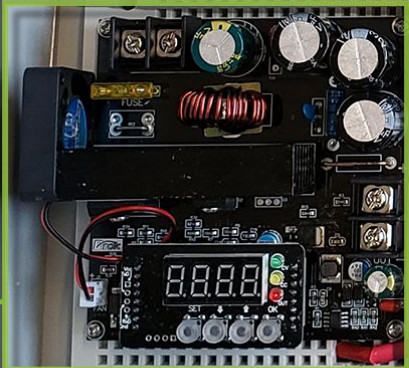

Power Supply
Voltage stepdown

54V Battery Pack
13 strings of 4 cells
Samsung 18650 3.6V cells

Data Pipeline

Current, Voltage & Temp
From Sensors

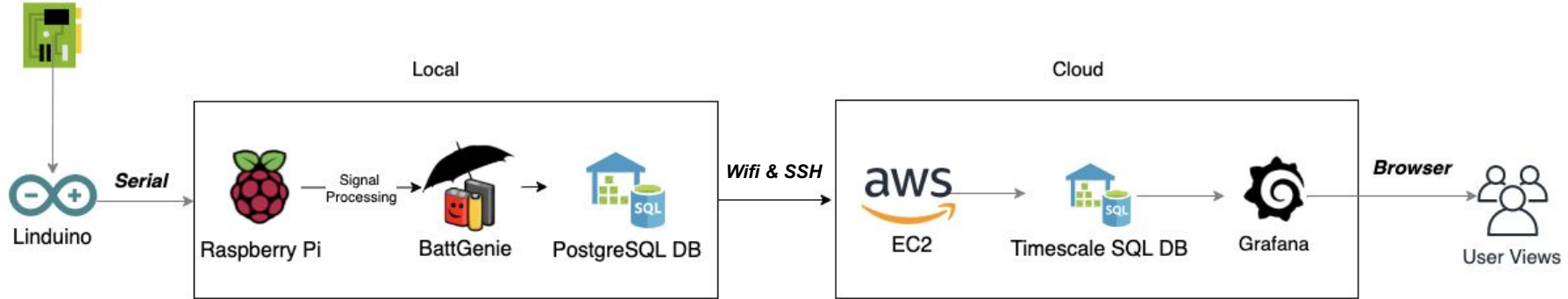

Software Architecture Diagram

Pack and Series Voltage

Voltage data at a macro and micro view

Current, Temperature, Power

Basic metrics of battery performance



State of Charge

Output of BattGenie algorithm

Raw Data Table

Enables further analysis

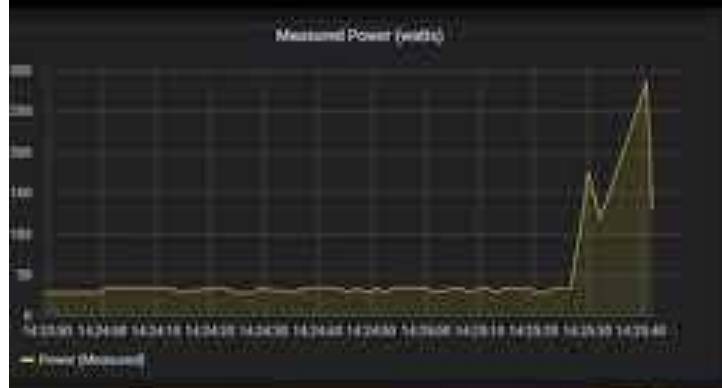

Demo of Data Pipeline

Roadmap

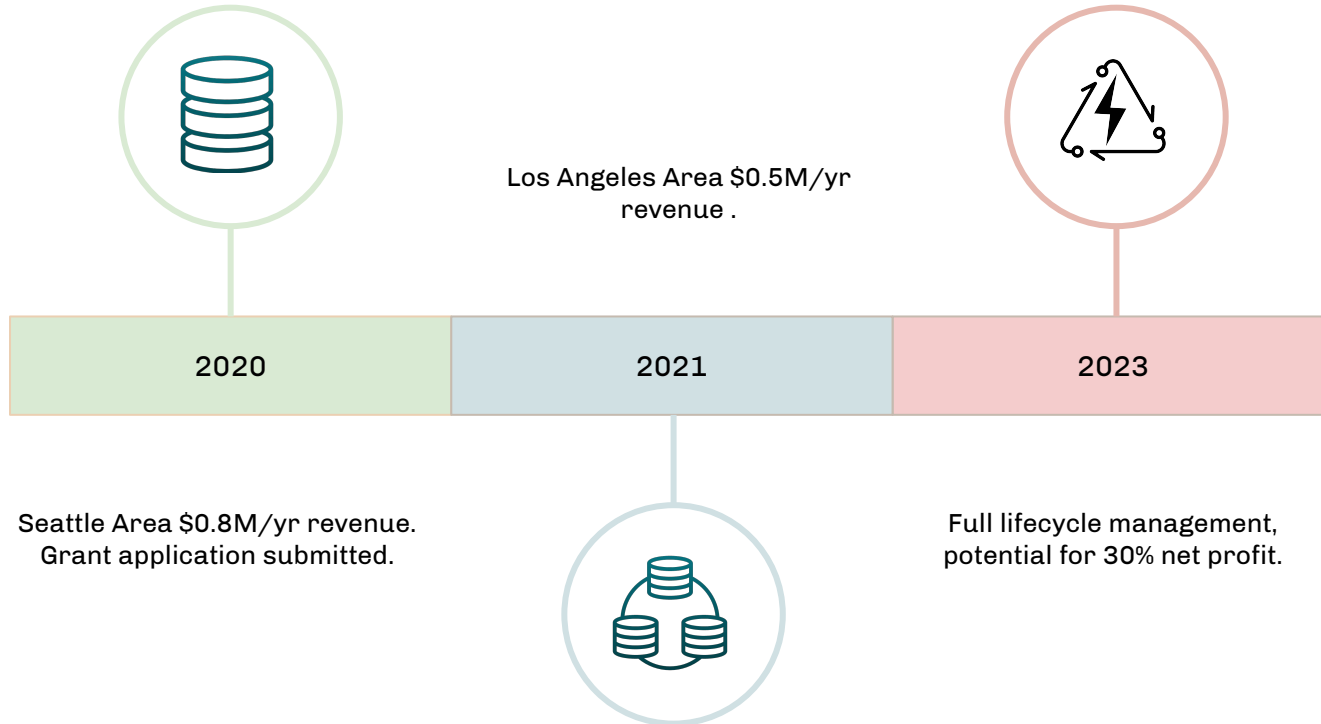

Thank You:
BattGenie: Manan & Chintan
GIX Faculty & Staff
Our parents

References

- [1] Ahmadi, L., Yip, A., Fowler, M., Young, S. B., & Fraser, R. A. (2014). Environmental feasibility of re-use of electric vehicle batteries. *Sustainable Energy Technologies and Assessments*, 6, 64-74.
- [2] Bobba, Silvia, et al. "Life Cycle Assessment of repurposed electric vehicle batteries: an adapted method based on modelling energy flows." *Journal of Energy Storage* 19 (2018): 213-225.
- [3] Beer, S., Gomez, T., Dallinger, D., Momber, I., Marnay, C., Stadler, M., & Lai, J. (2012). An Economic Analysis of Used Electric Vehicle Batteries Integrated Into Commercial Building Microgrids. *IEEE Transactions on Smart Grid*, 3(1), 517-525. <https://doi.org/10.1109/TSG.2011.2163091>
- [4] Elkind, E. (2014). Reuse and Repower: How to save money and clean the grid with second-life electric vehicle batteries.
- [5] Jiao, N., & Evans, S. (2016). Business Models for Sustainability: The Case of Second-life Electric Vehicle Batteries. *Procedia CIRP*, 40, 250-255. <https://doi.org/10.1016/j.procir.2016.01.114>
- [6] Stringer, D., & Ma, J. (2018, June 27). *Where 3 Million Electric Vehicle Batteries Will Go When They Retire*. Retrieved from <https://www.bloomberg.com/news/features/2018-06-27/where-3-million-electric-vehicle-batteries-will-go-when-they-retire>
- [7] Linnenkoper, K. (2015, September 30). World battery market worth US\$ 60 billion • Recycling International. Retrieved July 11, 2019, from Recycling International website: <https://recyclinginternational.com/e-scrap/world-battery-market-worth-us-60-billion/4560/>
- [8] https://www.marketsandmarkets.com/Market-Reports/electric-vehicle-battery-market-100188347.html?clid=FAIaIQobChMIhpO-mIVe5AIVSdbACh0PBwpCEAAAYASAAEgIcI_D_BwE
- [9] <https://www.forbes.com/sites/rRAPier/2019/08/04/why-china-is-dominating-lithium-ion-battery-production/#1865d7b03786>
- [10] <https://www.visiongain.com/report/lithium-ion-battery-market-report-2019-2029/> <https://finance.yahoo.com/news/visiongain-report-offers-transformative-insights-090000660.html>
- [11] <https://www.utilitydive.com/news/global-lithium-ion-battery-market-expected-to-exceed-60b-by-2024-report/546108/>
- [12] <https://www.forbes.com/sites/rRAPier/2019/08/04/why-china-is-dominating-lithium-ion-battery-production/#1865d7b03786>
- [13] <https://www.bloomberg.com/news/articles/2018-10-11/here-s-where-telsa-s-supplier-says-the-lithium-market-is-heading>
- [14] <https://www.energy-storage.news/blogs/recycle-vs-reuse-why-ev-batteries-may-not-often-get-a-second-life-as-statio>
- [15] <https://www.idtechex.com/en/research-report/second-life-electric-vehicle-batteries-2020-2030/681>
- [16] <http://www.programmersought.com/article/2717710023/>
- [17] <https://www.mckinsey.com/industries/automotive-and-assembly/our-insights/second-life-ev-batteries-the-newest-value-pool-in-energy-storage>
- [18] <https://www.pv-magazine.com/2018/08/03/second-life-ev-battery-market-to-grow-to-4-2-billion-by-2025/>
- [19] <https://www.iaii.it/en/publicazioni/rise-lithium-batteries-new-form-energy-dependence>
- [20] Camille Grosjean et al., "Assessment of World Lithium Resources and Consequences of Their Geographic Distribution on the Expected Development of the Electric Vehicle Industry",
- [21] <https://www.wired.co.uk/article/lithium-batteries-environment-impact>
- [22] <https://electricvehiclebatteries.pro/2019/07/25/second-life-electric-vehicle-batteries-2019-2029-idtechex/>
- [23] <https://www.mckinsey.com/business-functions/sustainability/our-insights/battery-technology-charges-ahead>
- [24] <https://www.prnewswire.com/news-releases/demand-for-lithium-is-growing-rapidly-as-li-ion-batteries-usage-continues-to-expand-683691101.html>
- [25] <https://www.energy.gov/eere/articles/energy-department-announces-phase-1-winners-battery-recycling-prize>
- [26] <https://arstechnica.com/science/2019/02/electric-car-batteries-might-be-worth-recycling-but-bus-batteries-arent-yet/>
- [27] https://www.marketwatch.com/press-release/electric-bus-market-size-share-trends-forecast-to-2025-cagr-2564-2019-07-26?mod=mw_quote_news
- [28] Hawkins, Troy & Singh, Bhawna & Majeau-Bettez, Guillaume & Strömman, Anders. (2013). Comparative Environmental Life Cycle Assessment of Conventional and Electric Vehicles. *Journal of Industrial Ecology*, 17. 10.1111/j.1530-9290.2012.00532.x.